

## WALL MOUNT DOUBLE SECTION CABINET

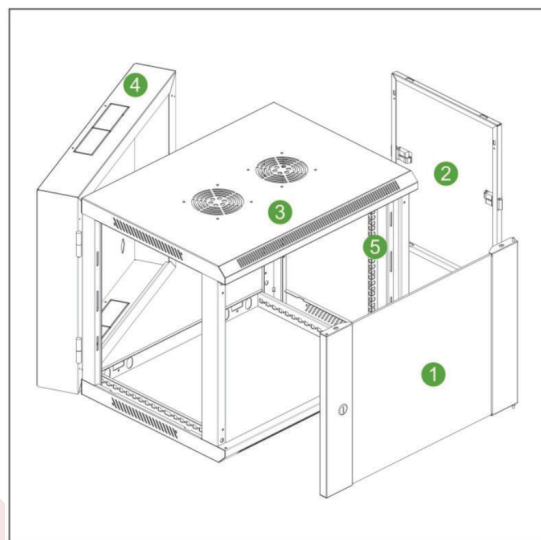

### Feature

- Double section welded frame structure;
- Easy operation and maintenance at the back;
- 19" standard installation;
- Removable side panels, side locks are optional, easy installation and maintenance;
- Cable entry on the top cover and bottom panel;
- 120mm fan optional;
- Turning angle of front door is above 180 degree;
- Turning angle of rear door is above 90 degree;

### Main Part

S/N	Specification	Qty	Material	Surface Finish	Remark
1	Front door	1	5mm toughed glass door/SPCCt1.2	Powder coated	May choose the fitting, See page 86
2	Side panel	2	SPCC t1.0	Powder coated	----
3	Front frame	1	SPCC t1.2	Powder coated	----
4	Back frame	1	SPCC t1.2	Powder coated	----
5	19" rails	4	SPCC t1.2	Powder coated	20pcs for over 12U
A	M6 screw & nuts	10	Steel	Color zinc	----
B	Torx tooling	1	Steel	Black	----

### Ordering Information

FS	00	00	00	-0000	
Part Number	Capacity (U)	Width (mm)	Depth (mm)	Color Code	Height (mm)
WMDS	4	600	550	9004:- RAL 9004 (BLACK)	245
	6	600	550	7035:- RAL 7035 (GREY)	370
	9	600	550	9010:- RAL 9010 (OFF-WHITE)	500
	12	600	550		635
	15	600	550		770
	18	600	550		900